

The HM57 five valve manifold combines two shutoff valves, two equalizing valves, and a vent/calibration valve into a single, compact assembly. The double equalizing arrangement insures against measurement error that can occur from equalizer leakage between high and low pressure connections, making the HM57 ideal for custody transfer applications.

When expensive liquid or gas changes ownership, precise measurement is critical. The smallest leakage from the high side of the manifold to the low side of the manifold can lead to lost revenue due to inaccurate measurement. Therefore, when dealing with custody transfer or other critical flows, a five valve manifold should be used to achieve more accurate measurement. The number of threaded connections is greatly reduced when using the HM57 instead of needle valves, piping and tees, and, with fewer connections, there are fewer potential leak points and reduced risk of fugitive emissions.

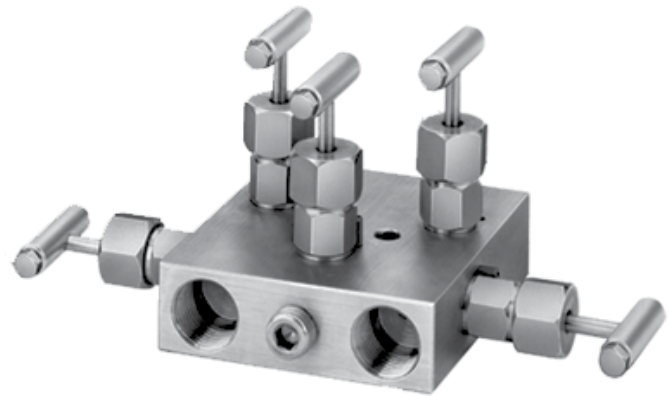

Features and Benefits

- **Reduce costs and installation time:** Using Hex five valve manifolds in place of the conventional arrangement of five individual needle valves, piping and tees provides a streamlined, low cost, easy to install assembly
- **Integral vent/calibration valve:** Shutoff, equalizing and vent/calibration functions are provided in one compact valve body weighing only 3.75 pounds (1,7 kgs). Technicians can perform zeroing and calibration procedures at the manifold location with a minimum of tools.
- **Fewer leak points:** The number of threaded connections are greatly reduced when using the HM57 in lieu of needle valves, piping and tees. With fewer connections, there are fewer potential leak points and reduced risk of fugitive emissions
- **Your choice of mounting styles:** Available with threaded by threaded, threaded by flanged, or flanged by flanged connections to meet a variety of mounting requirements

Flow Schematic

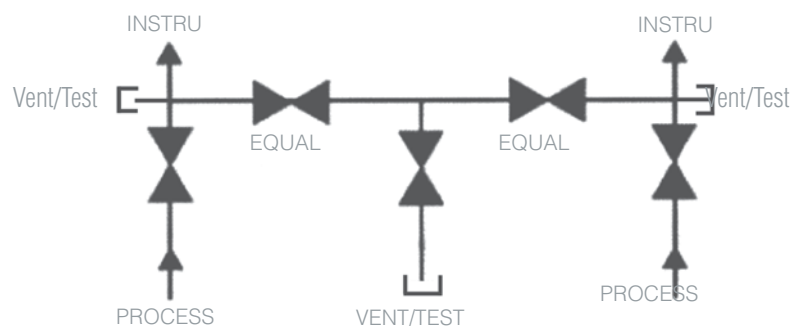

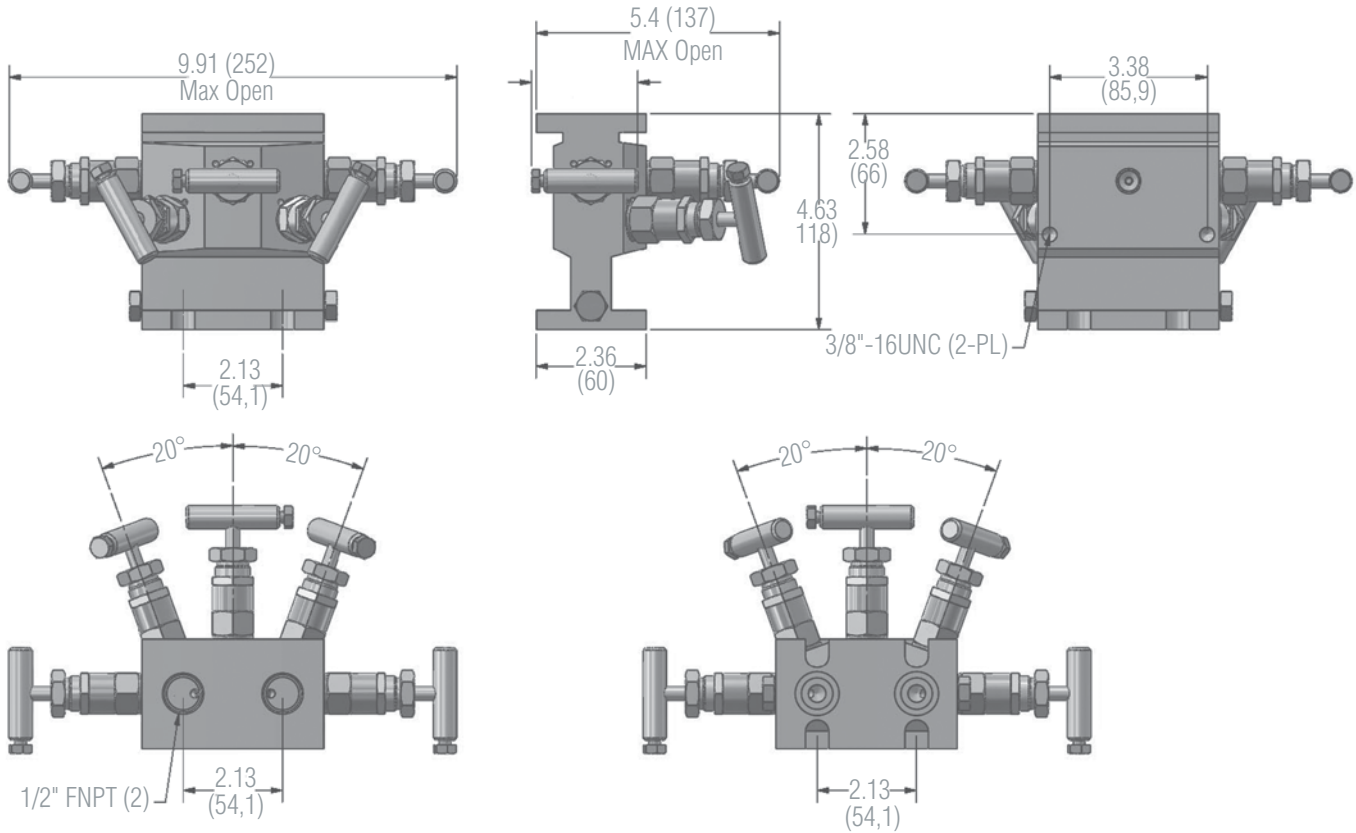
Dimensions

How to Order									
Model Number	Seat/ Body Configuration	Body Material	Inlet Size	Inlet Type	Outlet Size	Outlet Type	Stem/Tip	Seat Material	Packing
HM57	1 = Hard (6000 psi)	S = CS	3 = 1/2"	3 = FNPT	3 = 1/2"	1 = FNPT	2 = 316SS Needle/Plug (Soft seat only)	1 = Integral (hard)	3 = Graphite
	2 = Soft (3000 psi)	U = SS	9 = Flanged	A = Tube Nut	A = 1/2" Single Ferrule Integral Tube Nut	8 = Tube Nut	4 = 316/316SS NRT	B = Acetal	6 = Viton/O-Ring
	G = Soft Seat / O-Ring (3000 psi)			9 = Flanged	B = 1/2" Double Ferrule Integral Tube Nut	9 = Flanged			
					9 = Flanged				

Sample Ordering Schematic

HM57	1	S	3	3	3	1	2	1	3
------	---	---	---	---	---	---	---	---	---